

NAPIER UNIVERSITY
SCHOOL OF COMPUTING

FIRST DIET (SEMESTER ONE) EXAMINATION

SESSION 2001-2002

MODULE: CO32006

COMPUTER NETWORKS AND DISTRIBUTED SYSTEMS

DATE:

DURATION: 2 HOURS

START TIME:

EXAMINER(S)

DR. W. BUCHANAN

QUESTION PAPER DATA

Number of pages - 10
Number of questions - 40
Number of sections - THREE

INSTRUCTION TO CANDIDATES

Please enter your matriculation number at the bottom of each page.

SECTION A: The following questions are multiple-choice, and you will lose marks for the incorrect answer. Please select answers for each of the questions, and enter it into the box provided. For example:

Q What is two plus two: [1]

- (A) 1
- (B) 2
- (C) 3
- (D) 4

1 What must be common to computers if they are to communicate over a network: [1]

- (A) Use the same operating system
- (B) Use the same networking model
- (C) Use the same protocol
- (D) Manufactured by the same company
- (E) Use similar hardware

2 The default networking protocol used by Novell NetWare is: [1]

- (A) Ethernet
- (B) TCP/IP
- (C) SPX/IPX
- (D) NetBEUI
- (E) Token Ring

3 Which of the following is the main disadvantage of a star network: [1]

- (A) That the data transmitted between the central server and the node to server traffic is relatively high compared to other network topologies
- (B) That the network is reliant on a central server
- (C) All nodes compete for the network
- (D) Nodes can only transmit data once they have a token
- (E) Data on star networks cannot be sent to other types of networks

4 Which service allows hosts to determine the IP address for a given domain name: [1]

- (A) RARP
- (B) TCP
- (C) ICMP
- (D) ARP
- (E) DNS

5 Which protocol is used by a node to determine the IP address for a given Ethernet address: [1]

- (A) TCP
- (B) RARP
- (C) ICMP
- (D) ARP
- (E) DNS

6 Which Ethernet address (in hexadecimal format) is used for broadcast messages: [1]

- (A) FF-FF-FF-FF-FF-FF
- (B) 01-01-01-01-01-01
- (C) 11-11-11-11-11-11
- (D) 00-00-00-00-00-00
- (E) AA-AA-AA-AA-AA-AA

7 How is the initial sequence number of a TCP packet generated: [1]

- (A) Randomly
- (B) From the current date and time
- (C) From a 32-bit clock which is updated every 4 μ s
- (D) From a universal Internet-based clock
- (E) From the system clock

8 Which of the following best describes a function of the session layer: [1]

- (A) Formats the data into a data frame which can be sent over the network
- (B) Segments the data into data segments
- (C) Encrypts and prepares the data for transmission
- (D) Establishes, manages and terminates communication between applications.
- (E) Routes data packets around the network

9 Which of the following best describes a function of the transport layer: [1]

- (A) Segment and reassemble segments into a data stream
- (B) Establishes, maintains and terminates sessions between applications
- (C) Encrypts and prepares the data for transmission
- (D) Routes data packets around interconnected networks
- (E) Formats data in a form which can be transmitted over the network

10 How does a node determine the MAC address of a node on another network: [1]

- (A) It requests it with an ARP request
- (B) It does not need it as it uses the network address, and the MAC address of the gateway
- (C) It does a DNS lookup for the address
- (D) It sends out a request for the IP address of the node
- (E) It sends out a broadcast to all the connected networks

11 When transmitting data, what is the correct order of data encapsulation: [1]

- (A) Bits→Frames→Packets→Segments→Data
- (B) Frames→Bits→Packets→Segments→Data
- (C) Bits→Frames→Segments→Packets→Data
- (D) Frames→Bits→Packets→Data →Segments
- (E) Bits→Frames→Packets→Data→Segments

12 Why do hosts use TCP flow control: [1]

- (A) To monitor network traffic
- (B) To provide info as to whether the remote computer is still communicating
- (C) To avoid their data buffers from overflowing
- (D) To interrupt the processor when the computer is busy
- (E) To create a constant flow of data

- 13 The main advantage that ATM has over traditional LAN technologies is that: [1]
- (A) It integrates well with existing LANs
 - (B) It is cheaper to implement
 - (C) It properly supports real-time and non-real-time traffic
 - (D) It is easier to interface to
 - (E) It properly supports TCP/IP
- 14 Which of the following **best** describes the function of a firewall: [1]
- (A) To provide a gateway for the rest of the network
 - (B) To disallow unwanted traffic into the network and allow wanted traffic
 - (C) To allow users access to the Internet
 - (D) To allow faster transfer of data between the Intranet and the Internet
 - (E) Allow one type of network to connect to another type
- 15 Which of the following **best** describes a proxy: [1]
- (A) It connects to a number of clients and acts on behalf of other clients and sends requests from the clients to a server
 - (B) It converts one type of network traffic to another
 - (C) A server that acts as if it is the destination server
 - (D) It passes messages to the client or server without modifying them
 - (E) It stores responses
- 16 For the TCP sequence given next, determine which of the following is true for the next data packet sequence for the Node-A and the Node-B: [1]
- (A) Node-A will send 1000 and the Node-B will send 100
 - (B) Node-A will send 1001 and the Node-B will send 100
 - (C) Node-A will send 1000 and the Node-B will send 101
 - (D) Node-A will send 1001 and the Node-B will send 101
 - (E) Node-A will send 1002 and the Node-B will send 101

Node-A

1. CLOSED
2. SYN-SENT → <SEQ=999><CTL=SYN>
3. ESTABLISHED <SEQ=100><ACK=1000><CTL=SYN,ACK>
4. ESTABLISHED → <SEQ=1000><ACK=101><CTL=ACK><DATA>

Node-B

- LISTEN
- SYN-RECEIVED
- SYN-RECEIVED ←
- ESTABLISHED

- 17 Which of the following **best** describes a permanent circuit in ATM: [1]
- (A) A route that is permanently reserved with VCI labels
 - (B) Data will always be sent over the connection
 - (C) A route that can involve multiple channels
 - (D) There is no real-time data involved in the connection
 - (E) The route always has a permanently defined Quality of Service

- 18** With WWW page integration, which of the following are always true with client-side and server-side includes (select one or more): [1]
- (A) The WWW server processes client-side includes, while the WWW browser processes server-side includes
 - (B) The WWW browser processes client-side includes, while the WWW server processes server-side includes
 - (C) In client-side includes, the WWW server converts the client-side include into HTML
 - (D) In server-side includes, the WWW browser converts the server-side include into HTML
 - (E) In server-side includes, the WWW client converts the server-side include into HTML
- 19** Which event is used in Visual Basic to identify that data has been received over the network: [1]
- (A) DataArrival
 - (B) Connect
 - (C) Listen
 - (D) SendData
 - (E) ConnectionRequest
- 20** Which of the following is a MAC address: [1]
- (A) 0000.0E64.5432
 - (B) 146.176.151.130
 - (C) mac.address.com
 - (D) F5332B10:00000E645432
 - (E) NETPRINTER

SECTION B: The following questions are fixed-format answers. Please insert your answer in the box provided. Note you will not lose any marks if you have the incorrect answer, and that you may gain marks if you are almost correct.

21 Identify two VB methods which would be used in a server program, and not in a client program: [2]

22 If a network has Class B IP addresses with 10 subnets, what will the subnet mask be: [2]

23 If a network has Class C IP addresses with 50 subnets, what will the subnet mask be: [2]

24 If a network has Class B IP addresses of the form 146.176.y.z and has 14 subnets. What is the first network address: [2]

25 If nodes connect to a network which has been allocated the address of 130.10.y.z and use a subnet mask of 255.255.248.0. What will be the first allocatable address for a host on the third subnet: [3]

26 If nodes connect to a network which has been allocated the address of 130.10.y.z and use a subnet mask of 255.255.248.0. What will be the last allocatable address for a host on the third subnet: [2]

27 For the PHP script given next, determine the line which contains a syntax error, and identify it: [1]

```
Line (A) <?php
Line (B) $value=0; /our variable
Line (C) while($value<=10){
Line (D)     print (" $value = " .($value*$value));
Line (E)     print("<br>\n");
Line (F)     $value=$value+1;
Line (G) }
Line (H) ?>
```

28 For the XML file given below, determine the lines which contains a syntax error: [2]

```
Line (A) <xml version="1.0" encoding="iso-8859-1"?><!DOCTYPE questions>
Line (B) <questions>
Line (C) <no_questions>15</no_questions>
Line (D) <subject>Introduction to Computing</subject>
Line (E) <quest id="000001">
Line (F) <title>How many bits are in a nibble:</title>
Line (G) <q1>4</q1>
Line (H) <q2>8</q2>
Line (I) <q3>16</q3>
Line (J) <q4>32</q4>
Line (K) <q5>Answer a5</q5>
Line (L) <correct>q1</correct>
Line (M) <level>1
Line (N) </quest>
Line (O) <quest id="000002">
Line (P) <title>Which unit represents 1024 bytes:</title>
Line (Q) <q1>B</q1>
Line (R) <q2>KB</q2>
Line (S) <q3>MB</q3>
Line (T) <q4>GB</q4>
Line (U) <q5>Answer b5</q5>
Line (V) <correct>q2</correct>
Line (W) <level>2
Line (X) </quest>
Line (Y) </question>
```

29 For the PHP code given next, determine an outline of the output: [2]

```
$i=0;
do
{
    $i++;
    $x=$i*$i;
    print "[$i $x] ";
} while ($i<11);
```

The following questions relate to the diagram given in Figure 1. There are four computers on two Ethernet networks (Dev-A, Dev-B, Dev-F and Dev-G), which are interconnected using a bridge (Dev-C) and two routers (Dev-D and Dev-E). The ports on the bridge and the router are identified by either a 1 or a 2.

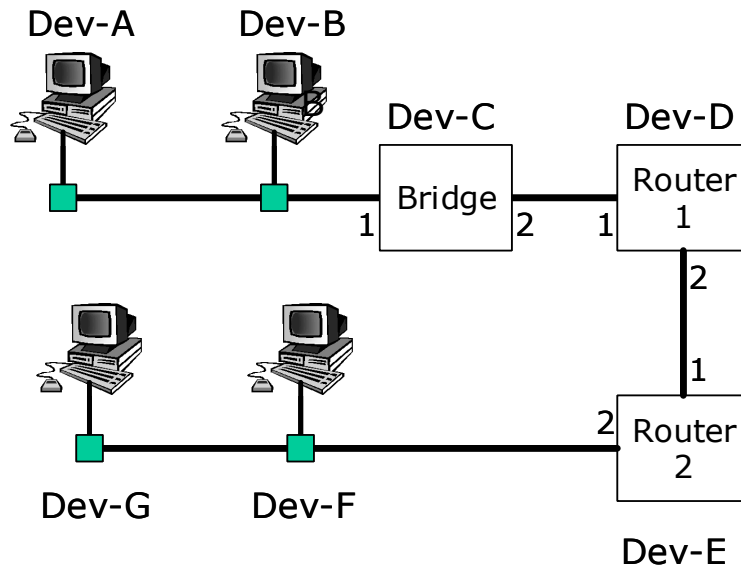
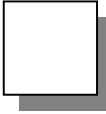
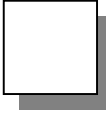
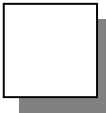
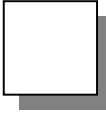
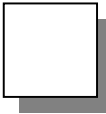
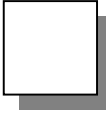

Figure 1: Two interconnected Ethernet networks

- 30 What is the minimum number of IP addresses which are required to be assigned for devices on each of the two Ethernet networks to intercommunicate, and explain why it is this number: [3]

- 31 If Dev-A is communicating with Dev-G, what destination IP address will be used in the data packet which is transmitted between Dev-D (Router 1) and Dev-E (Router 2): [1]
- | | |
|---------------------------------|---------------------------------|
| (A) IP address of Dev-A | (B) IP address of Dev-B |
| (C) IP address of Dev-F | (D) IP address of Dev-G |
| (E) IP address of Dev-C, Port 1 | (F) IP address of Dev-C, Port 2 |
| (G) IP address of Dev-D, Port 1 | (H) IP address of Dev-D, Port 2 |
| (I) IP address of Dev-E, Port 1 | (J) IP address of Dev-E, Port 2 |

- 32 If Dev-A is communicating with Dev-G, what source IP address will be used in the data packet which is transmitted between Dev-D (Router 1) and Dev-E (Router 2): [1]
- | | |
|---------------------------------|---------------------------------|
| (A) IP address of Dev-A | (B) IP address of Dev-B |
| (C) IP address of Dev-F | (D) IP address of Dev-G |
| (E) IP address of Dev-C, Port 1 | (F) IP address of Dev-C, Port 2 |
| (G) IP address of Dev-D, Port 1 | (H) IP address of Dev-D, Port 2 |
| (I) IP address of Dev-E, Port 1 | (J) IP address of Dev-E, Port 2 |

- 33 If Dev-A is communicating with Dev-G, what MAC address will be used in the data frame which is transmitted between Dev-D (Router 1) and Dev-E (Router 2): [2]
- | | | |
|----------------------------------|----------------------------------|---|
| (A) MAC address of Dev-A | (B) MAC address of Dev-B |  |
| (C) MAC address of Dev-F | (D) MAC address of Dev-G | |
| (E) MAC address of Dev-C, Port 1 | (F) MAC address of Dev-C, Port 2 | |
| (G) MAC address of Dev-D, Port 1 | (H) MAC address of Dev-D, Port 2 | |
| (I) MAC address of Dev-E, Port 1 | (J) MAC address of Dev-E, Port 2 | |
- 34 For Dev-A, where is the end of its collision domain: [2]
- | | | |
|-------------------|-------------------|---|
| (A) Dev-A | (B) Dev-B |  |
| (C) Dev-F | (D) Dev-G | |
| (E) Dev-C, Port 1 | (F) Dev-C, Port 2 | |
| (G) Dev-D, Port 1 | (H) Dev-D, Port 2 | |
| (I) Dev-E, Port 1 | (J) Dev-E, Port 2 | |
- 35 For Dev-A, where is the end of its broadcast domain: [2]
- | | | |
|-------------------|-------------------|---|
| (A) Dev-A | (B) Dev-B |  |
| (C) Dev-F | (D) Dev-G | |
| (E) Dev-C, Port 1 | (F) Dev-C, Port 2 | |
| (G) Dev-D, Port 1 | (H) Dev-D, Port 2 | |
| (I) Dev-E, Port 1 | (J) Dev-E, Port 2 | |
- 36 If Dev-A is communicating with Dev-G what MAC address does it initially use to send a data frame: [2]
- | | | |
|----------------------------------|----------------------------------|---|
| (A) MAC address of Dev-A | (B) MAC address of Dev-B |  |
| (C) MAC address of Dev-F | (D) MAC address of Dev-G | |
| (E) MAC address of Dev-C, Port 1 | (F) MAC address of Dev-C, Port 2 | |
| (G) MAC address of Dev-D, Port 1 | (H) MAC address of Dev-D, Port 2 | |
| (I) MAC address of Dev-E, Port 1 | (J) MAC address of Dev-E, Port 2 | |
- 37 If Dev-A is communicating with Dev-G what destination IP address does it initially use to send a data packet: [1]
- | | | |
|----------------------------------|----------------------------------|---|
| (A) IP address of Dev-A | (B) IP address of Dev-B |  |
| (C) IP address of Dev-F | (D) IP address of Dev-G | |
| (E) IP address of Dev-C, Port 1 | (F) IP address of Dev-C, Port 2 | |
| (G) IP address of Dev-D, Port 1 | (H) IP address of Dev-D, Port 2 | |
| (I) MAC address of Dev-E, Port 1 | (J) MAC address of Dev-E, Port 2 | |
- 38 How many subnets can be created on a Class C network which uses a subnet mask of 255.255.255.192, and how many hosts can connect to **each** subnet: [2]
- | | | |
|------------------------------|-------------------------------|---|
| (A) 2 subnets, and 254 hosts | (B) 4 subnets, and 254 hosts |  |
| (C) 4 subnets, and 255 hosts | (D) 8 subnets, and 255 hosts | |
| (E) 8 subnets, and 256 hosts | (F) 16 subnets, and 256 hosts | |
| (G) 2 subnets, and 30 hosts | (H) 4 subnets, and 30 hosts | |
| (I) 2 subnets, and 62 hosts | (J) 4 subnets, and 64 hosts | |

SECTION C: The following questions are essay type questions, and should be completed in your answer book.

- 39** Explain why TCP can be described as a robust, connection-oriented protocol, whereas IP is connection-less, and non-robust. [10]
- 40** Explain, with reference to the UDP header, why UDP is not connection-oriented, and a system might use UDP, but still detect errors? [5]

WHEN YOU HAVE COMPLETED THIS EXAM, PLEASE ATTACH THIS BOOKLET
TO YOUR ANSWER BOOK.